

REV.	ECN NO.	MODIFIED MARK	APPROVED
A		FIRST RELEASE	

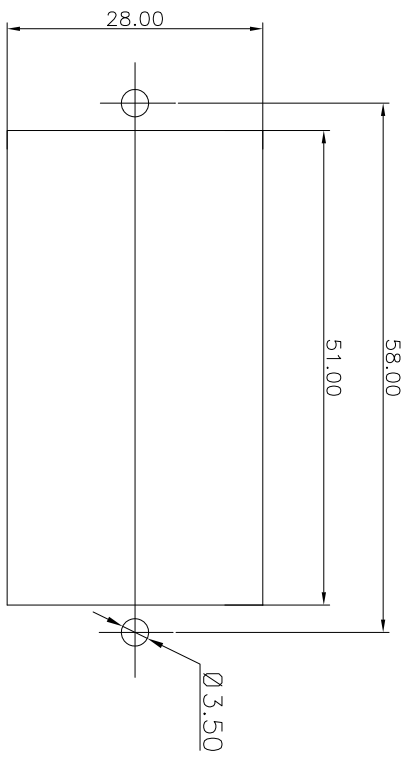

PANEL CUT OUT

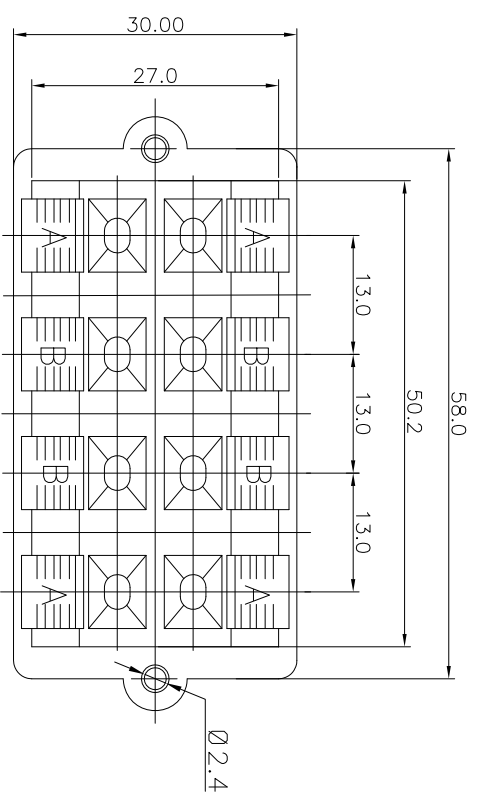
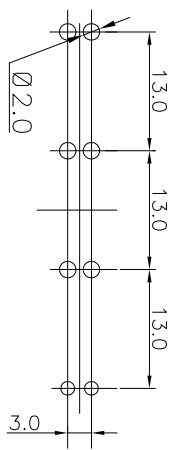
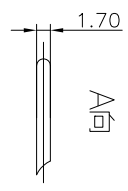
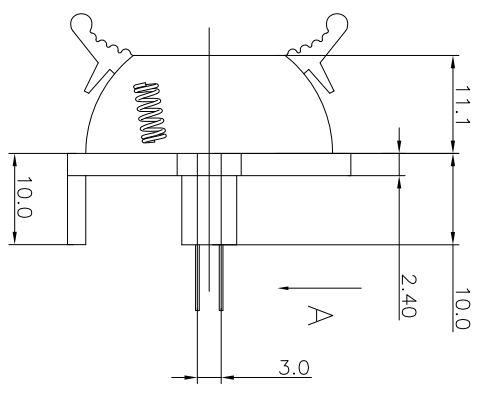

PCB LAYOUT
TOP VIEW

- NOTES:
- ELECTRICAL:
- 1:RATED CURRENT: 3A Max.
 - 2:RATED VOLTAGE: 50V AC.
 - 3:INSULATION RESISTANCE: 100 MEGAOHMS Min.
 - 4:DIELECTRIC WITHSTANDING VOLTAGE: 1200 VAC Min.
- MECHANICAL:
- 1:WIRE IN HOLD FORCE 5N (20#WIRE) MIN
 - 2:INSPECTED VOLTAGE, AT THE SPEED OF 6-10S PER MINUTES, THE SAMPLES ARE INSPECTED 10000 CYCLES, BUT THERE ARE NO DAMAGE ON THE PRESSURE AND THE RISING TEMPERATURE, ETC.3:APPLY 2kgf FORCE AT ANY DIRECTION , THERE NO LOOSE & NO CRACK

ANGLE	±5°	MODEL NAME: WP8-4A	 广东正宝科技有限公司 GUANGDONG TRENPPO TECHNOLOGY CO. LTD.
63 < L	±0.5	(PART NO.)	
16 < L ≤ 63	±0.4	DESIGN: X.H.Wang 11/06'18	TITLE: WP PUSH TERMINAL
4 < L ≤ 16	±0.3	CHECKED: L.W.Wu 11/06'18	DWG NO.:
L ≤ 4	±0.2	MAT'L: See table	UNIT: mm
TOL TABLE:		FINISH: See table	VIEW:
THIS DOCUMENT IS THE PROPERTY OF TRENPPO TECHNOLOGY CO. LTD. NO PART THEREOF MAY BE REPRODUCED AND USED WITHOUT THE PRIOR WRITTEN CONSENT OF THE OWNER		Q'TY: /	SCALE: 5:1
		APPROVED: X.Q.Hu 11/06'18	SHEET: 1/1
			SIZE: A3