

REV.:	ECN NO.:	MODIFIED MARK:	APPROVED:
A		FIRST RELEASE	

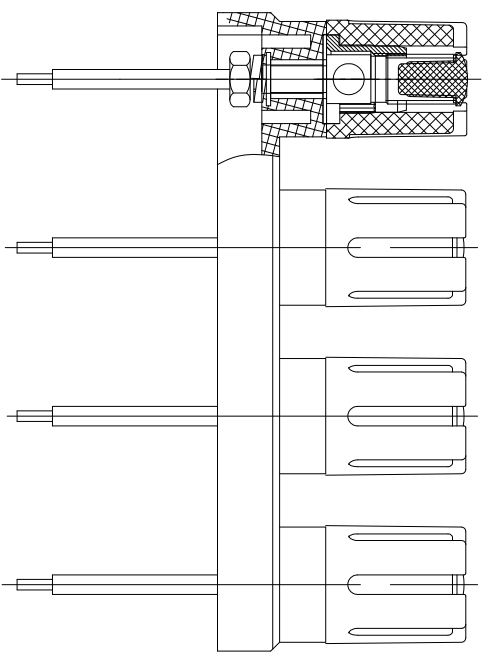
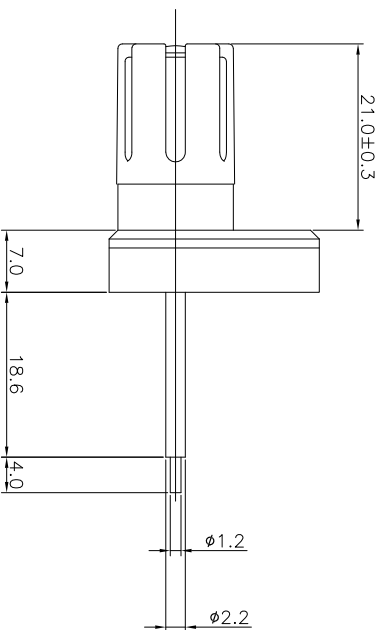
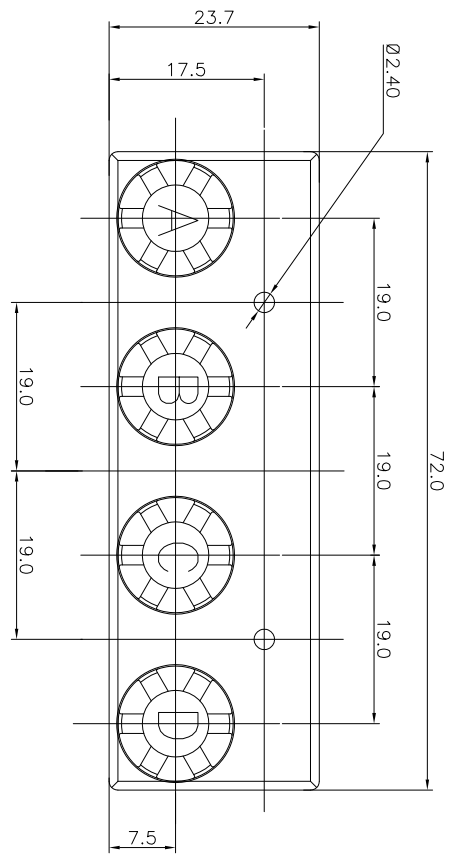

NOTES:
 ELECTRICAL:
 1: RATED CURRENT: 3A Max.
 2: RATED VOLTAGE: 50V AC.
 3: INSULATION RESISTANCE: 100 MEGAOHMS Min.
 4: DIELECTRIC WITHSTANDING VOLTAGE: 1200 VAC Min.
 MECHANICAL:
 1: WIRE IN HOLD FORCE 5N (20#WIRE) MIN
 2: INSPECTED VOLTAGE, AT THE SPEED OF 6-10S PER MINUTES, THE SAMPLES ARE INSPECTED 10000 CYCLES, BUT THERE ARE NO DAMAGE ON THE PRESSURE AND THE RISING TEMPERATURE, ETC.3.APPLY 2kgf FORCE AT ANY DIRECTION , THERE NO LOOSE & NO CRACK

ANGLE	±5°	MODEL NAME: WP4-24B	 广东正宝科技有限公司 GUANGDONG TRENPRO TECHNOLOGY CO. LTD.
63 < L	±0.5	(PART NO.)	
16 < L ≤ 63	±0.4	MAT'L:	DESIGN: X.H.Wang 11/06'18
4 < L ≤ 16	±0.3	FINISH:	CHECKED: L.W.Wu 11/06'18
L ≤ 4	±0.2	See table	TITLE: WP PUSH TERMINAL
TOL TABLE:		See table	UNIT: mm
THIS DOCUMENT IS THE PROPERTY OF TRENPRO TECHNOLOGY CO., LTD. NO PART THEREOF MAY BE REPRODUCED AND USED WITHOUT THE PRIOR WRITTEN CONSENT OF THE OWNER		Q'TY: /	APPROVED: X.Q.Hu 11/06'18
		VIEW:	SCALE: 5:1
		SHEET:	1/1
		SIZE:	A3