

REV.	ECN NO.	MODIFIED MARK	APPROVED
A		FIRST RELEASE	

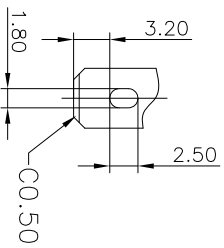
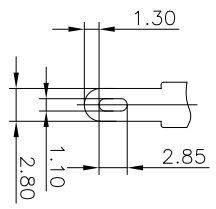
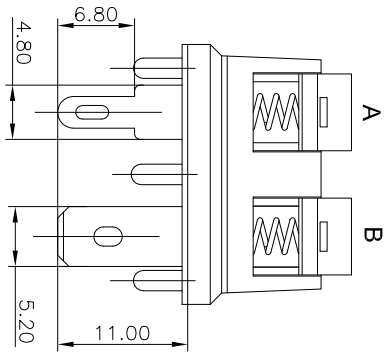
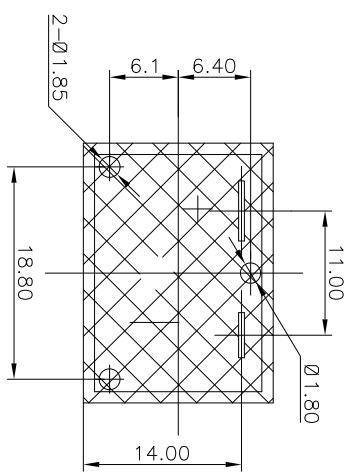
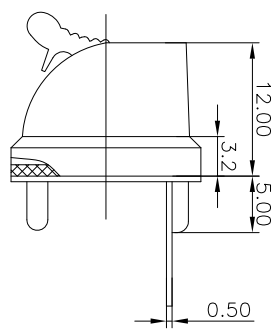
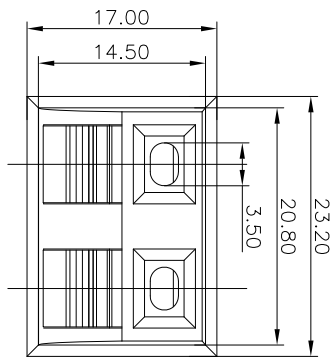

NOTES:  
 ELECTRICAL:  
 1:RATED CURRENT: 3A Max.  
 2:RATED VOLTAGE: 50V AC.  
 3:INSULATION RESISTANCE: 100 MEGAOHMS Min.  
 4:DILECTRIC WITHSTANDING VOLTAGE: 1200 VAC Min.  
 MECHANICAL:  
 1:WIRE IN HOLD FORCE 5N (20#WIRE) MIN  
 2:INSPECTED VOLTAGE, AT THE SPEED OF 6-10S PER MINUTES, THE SAMPLES ARE INSPECTED 10000 CYCLES, BUT THERE ARE NO DAMAGE ON THE PRESSURE AND THE RISING TEMPERATURE, ETC.3:APPLY 2kgf FORCE AT ANY DIRECTION , THERE NO LOOSE & NO CRACK

ANGLE	±5°	MODEL NAME: WP2-18A	 广东正宝科技有限公司 GUANGDONG TRENPPO TECHNOLOGY CO.,LTD.
63 < L	±0.5	(PART NO.)	
16 < L ≤ 63	±0.4		
4 < L ≤ 16	±0.3	MAT'L: DESIGN: X.H.Wang 09/13'18	TITLE: WP PUSH TERMINAL
L ≤ 4	±0.2	FINISH: CHECKED: L.W.Wu 09/13'18	DWG NO.:
TOL TABLE:		Q'TY: /	APPROVED: X.Q.Hu 09/13'18
THIS DOCUMENT IS THE PROPERTY OF ZHENHAI ELECTRONICS CO.,LTD. AND IT SHOULD NOT BE REPRODUCED AND USED WITHOUT THE PRIOR WRITTEN CONSENT OF THE OWNER		UNIT: mm	VIEW:
		SCALE: 5:1	SHEET: 1/1
		SIZE: A3	REV.: A