

REV.	ECN NO.	MODIFIED MARK	APPROVED
A		FIRST RELEASE	

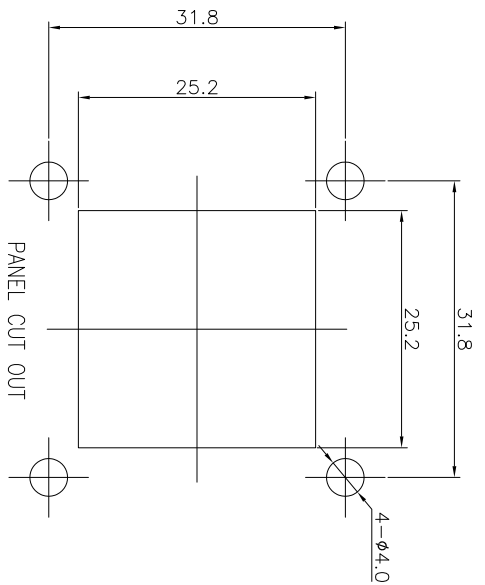
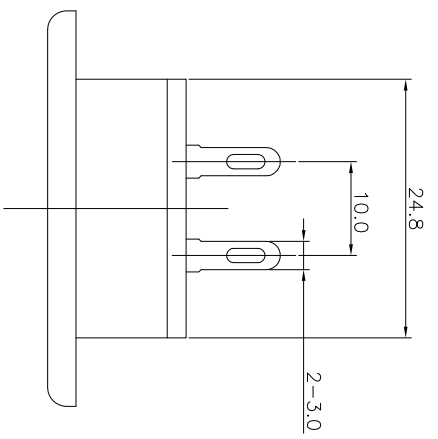
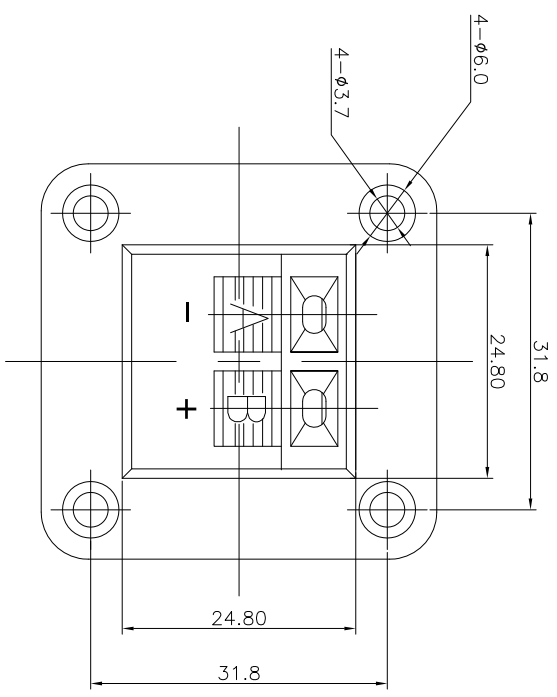
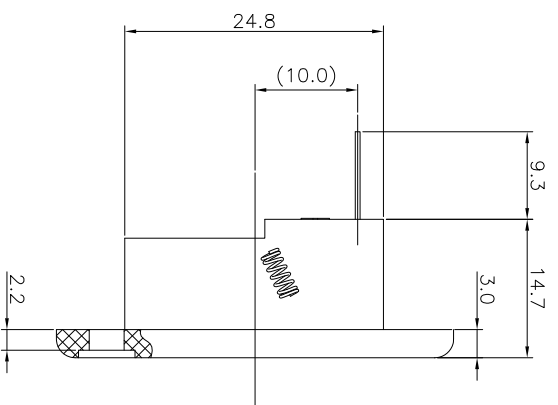
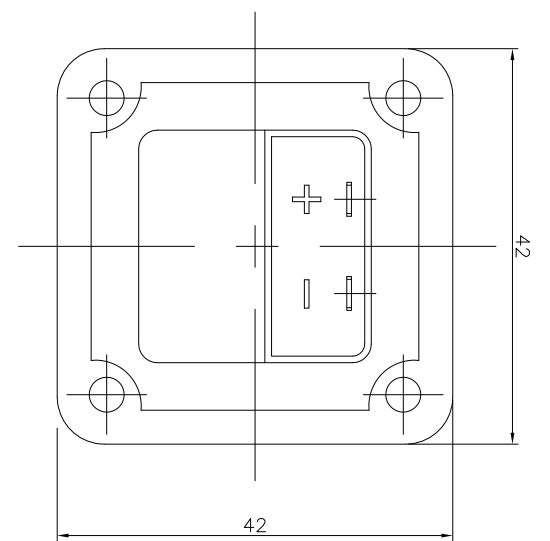

NOTES:
 ELECTRICAL:
 1: RATED CURRENT: 3A Max.
 2: RATED VOLTAGE: 50V AC.
 3: INSULATION RESISTANCE: 100 MEGAOHMS Min.
 4: DIELECTRIC WITHSTANDING VOLTAGE: 1200 VAC Min.
 MECHANICAL:
 1: WIRE IN HOLD FORCE 5N (20#WIRE) MIN
 2: INSPECTED VOLTAGE, AT THE SPEED OF 6-10S PER MINUTES, THE SAMPLES ARE INSPECTED 10000 CYCLES, BUT THERE ARE NO DAMAGE ON THE PRESSURE AND THE RISING TEMPERATURE, ETC. 3: APPLY 2kgf FORCE AT ANY DIRECTION, THERE NO LOOSE & NO CRACK

ANGLE	±5°
63 < L	±0.5
16 < L ≤ 63	±0.4
4 < L ≤ 16	±0.3
L ≤ 4	±0.2

MODEL NAME: WP2-5 (PART NO.)	DESIGN: X.H.Wang 11/06'18	TITLE: WP PUSH TERMINAL
MAT'L: See table	CHECKED: L.W.Wu 11/06'18	DWG NO.:
FINISH: See table	APPROVED: X.Q.Hu 11/06'18	UNIT: mm
Q'TY: /		VIEW: 5:1
		SCALE: SHEET: 1/1
		SIZE: A3

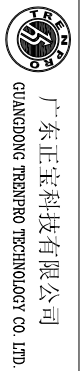

广东正宝科技有限公司
 GUANGDONG TRENPRO TECHNOLOGY CO., LTD.

TOL TABLE:
 THIS DOCUMENT IS THE PROPERTY OF TRENPRO TECHNOLOGY CO., LTD. NO PART THEREOF MAY BE REPRODUCED AND USED WITHOUT THE PRIOR WRITTEN CONSENT OF THE OWNER