

REV.	ECN NO.	MODIFIED MARK	APPROVED
A		FIRST RELEASE	

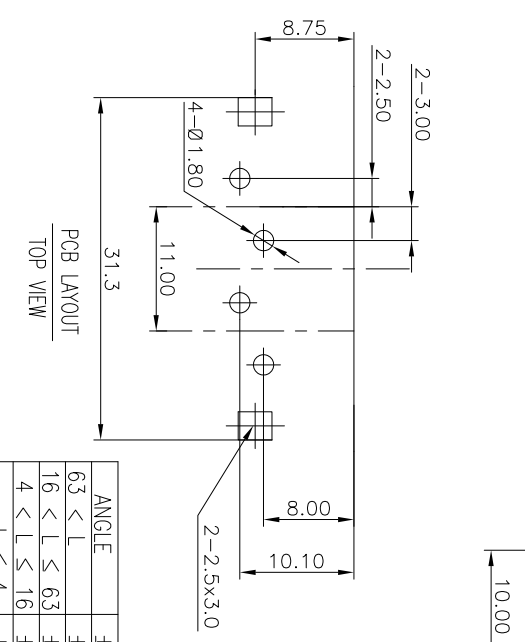
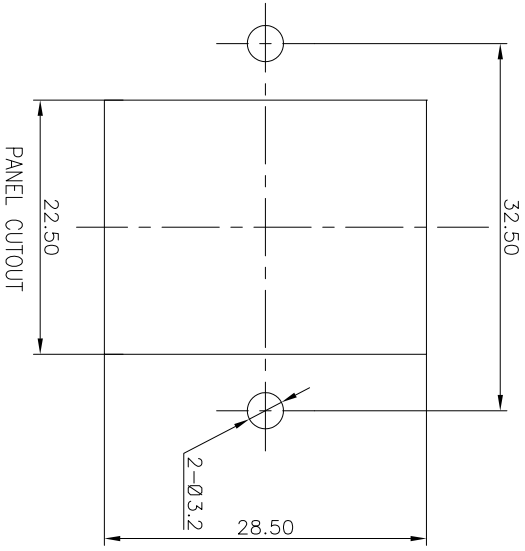
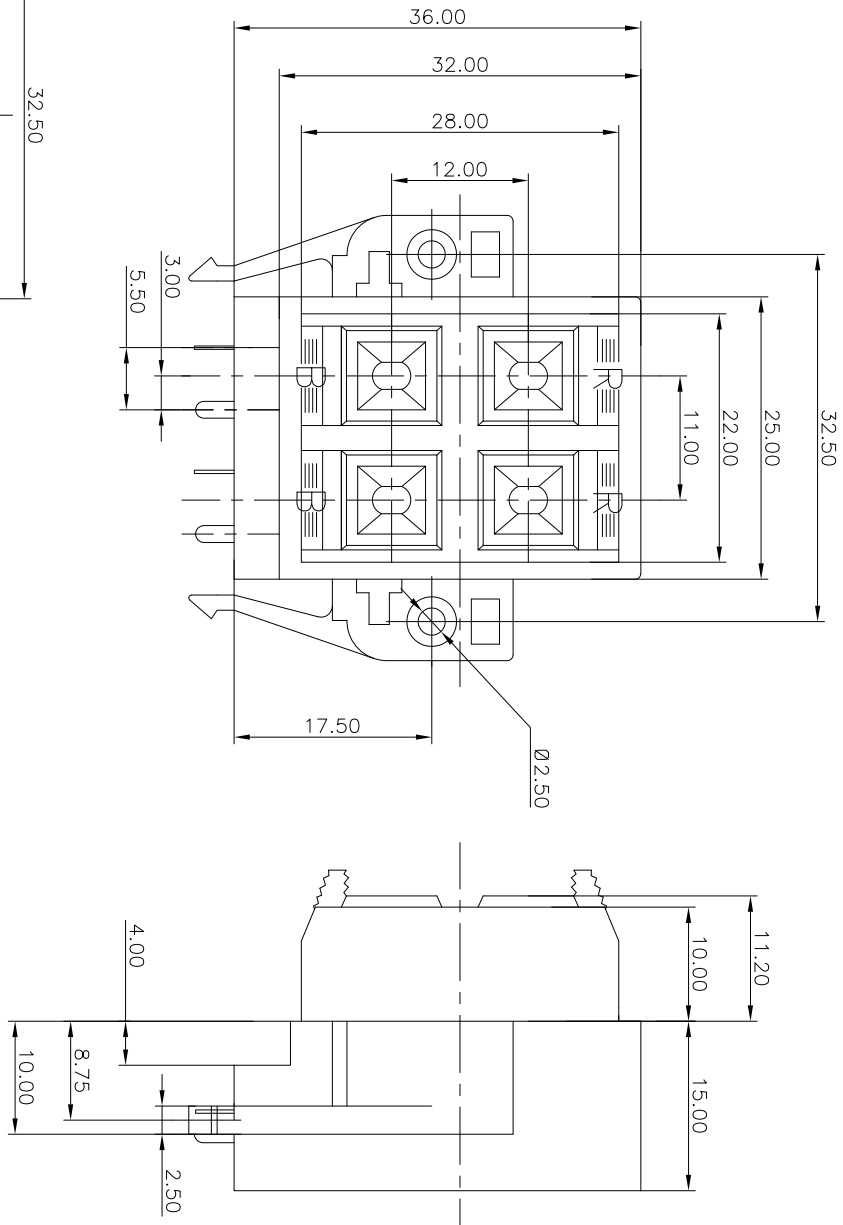

ANGLE	±5°
63 < L	±0.5
16 < L ≤ 63	±0.4
4 < L ≤ 16	±0.3
L ≤ 4	±0.2

MODEL NAME: WP4-17A/FB (PART NO.)		 广东正宝科技有限公司 GUANGDONG TERAPRO TECHNOLOGY CO., LTD.
DESIGN: X.H.Wang 09/13'18		
TITLE: WP PUSH TERMINAL		
CHECKED: L.W.Wu 09/13'18	DWG NO.:	

NOTES:

ELECTRICAL:

- 1: RATED CURRENT: 3A Max.
- 2: RATED VOLTAGE: 50V AC.
- 3: INSULATION RESISTANCE: 100 MEGAOHMS Min.
- 4: DIELECTRIC WITHSTANDING VOLTAGE: 1200 VAC Min.

MECHANICAL:

- 1: WIRE IN HOLD FORCE 5N (20#WIRE) MIN
- 2: INSPECTED VOLTAGE, AT THE SPEED OF 6-10S PER MINUTES, THE SAMPLES ARE INSPECTED 10000 CYCLES, BUT THERE ARE NO DAMAGE ON THE PRESSURE AND THE RISING TEMPERATURE, ETC.3: APPLY 2kgf FORCE AT ANY DIRECTION, THERE NO LOOSE & NO CRACK

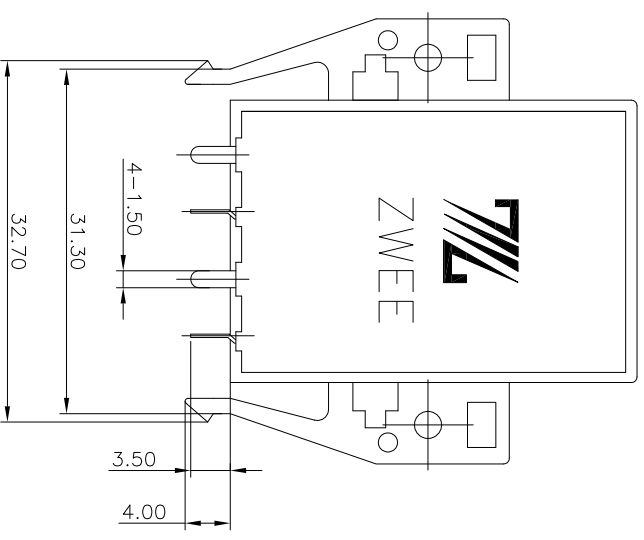

TOL TABLE:

THIS DOCUMENT IS THE PROPERTY OF TERAPRO TECHNOLOGY CO., LTD. NO PART THEREOF MAY BE REPRODUCED AND USED WITHOUT THE PRIOR WRITTEN CONSENT OF THE OWNER

QTY: /	APPROVED: X.Q.Hu 09/13'18	UNIT: mm	VIEW: 	SCALE: 5:1	SHEET: 1/1	SIZE: A3
--------	---------------------------	----------	--	------------	------------	----------