

REV.	ECN NO.	MODIFIED MARK	APPROVED
A		FIRST RELEASE	

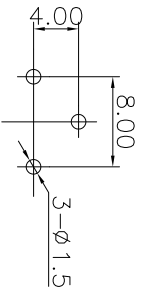

PCB LAYOUT
TOP VIEW

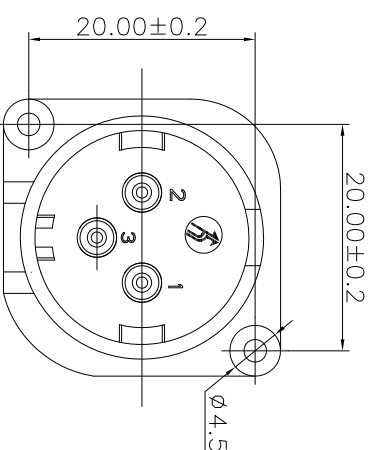
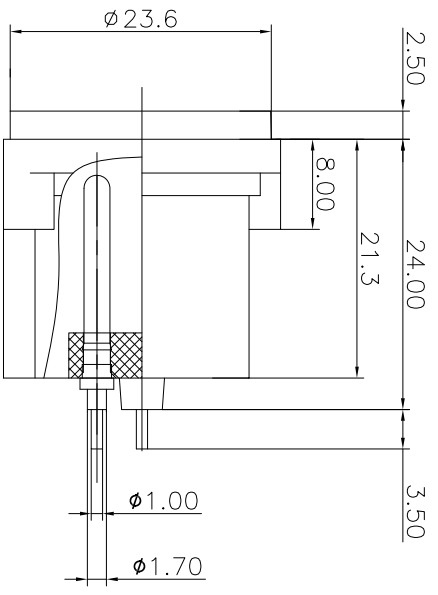
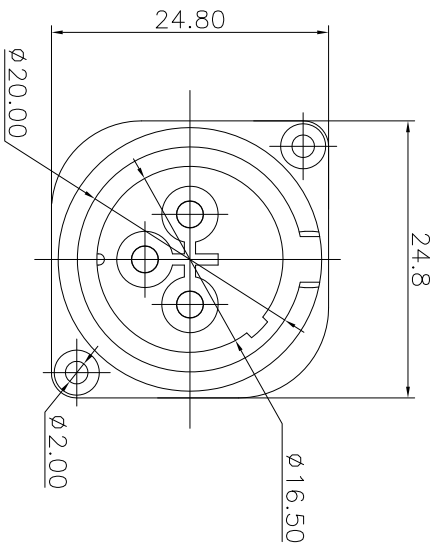
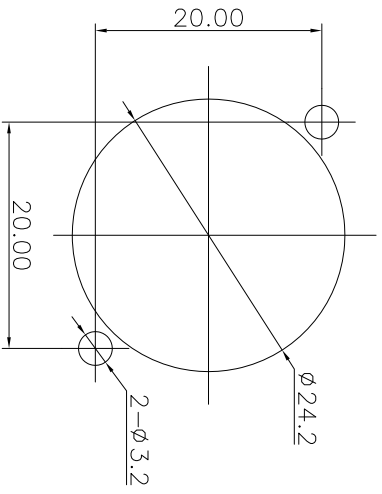

PANEL CUT OUT

- NOTES:
- ELECTRICAL:
- 1: RATED CURRENT: 6A Max.
 - 2: RATED VOLTAGE: 50V AC.
 - 3: CONTACT RESISTANCE: 30 MILLIOHMS Max. AFTER TESTING: 60 MILLIOHMS Max.
 - 4: INSULATION RESISTANCE: 1G OHMS Min.
 - 5: DIELECTRIC WITHSTANDING VOLTAGE: 500 VAC Min.
- MECHANICAL:
- 1: INSERTION FORCE: 5N-40N.
 - 2: WITHDRAWAL FORCE: 5N-40N.
 - 3: DURABILITY: 1000 CYCLES.
- ENVIRONMENTAL:
- TEMPERATURE RANGE: -30°C TO 80°C.

ANGLE	±5°	MODEL NAME: SPM-09C (PART NO.)	 广东正宝科技有限公司 GUANGDONG TRENPRO TECHNOLOGY CO., LTD.
63 < L	±0.5	MAT'L:	
16 < L ≤ 63	±0.4	FINISH:	
4 < L ≤ 16	±0.3	See table	
L ≤ 4	±0.2	Q'TY./	

TOL TABLE:		DESIGN: X.H.Wong 09/08'18	TITLE: XLR CABLE CONNECTORS	REV.: A
THIS DOCUMENT IS THE PROPERTY OF TRENPRO TECHNOLOGY CO., LTD. NO PART THEREOF MAY BE REPRODUCED AND USED WITHOUT THE PRIOR WRITTEN CONSENT OF THE OWNER		CHECKED: L.W.Wu 09/08'18	DWG NO.:	
APPROVED: X.Q.Hu 09/08'18	UNIT: mm	VIEW:	SCALE: 5:1	SHEET: 1/1
				SIZE: A3