

REV.	ECN NO.	MODIFIED MARK	APPROVED
A	—	FIRST RELEASE	

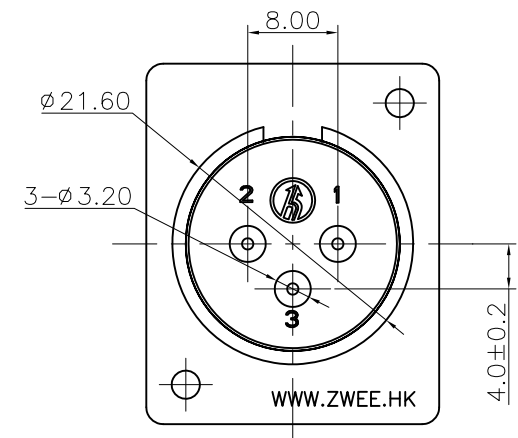

NOTES:  
 ELECTRICAL:  
 1:RATED CURRENT: 6A Max.  
 2:RATED VOLTAGE: 50V AC.  
 3:CONTACT RESISTANCE: 30 MILLIOHMS Max.  
 AFTER TESTING:60 MILLIOHMS Max.  
 4:INSULATION RESISTANCE: 1G OHMS Min.  
 5:DIELECTRIC WITHSTANDING VOLTAGE: 500 VAC Min.  
 MECHANICAL:  
 1:INSERTION FORCE: 5N-40N.  
 2:WITHDRAWAL FORCE: 5N-40N.  
 3:DURRABILITY: 1000 CYCLES.  
 ENVIRONMENTAL:  
 TEMPERATURE RANGE: -30°C TO 80°C.

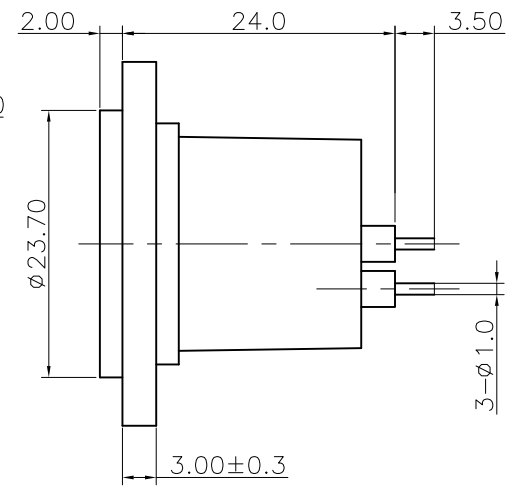
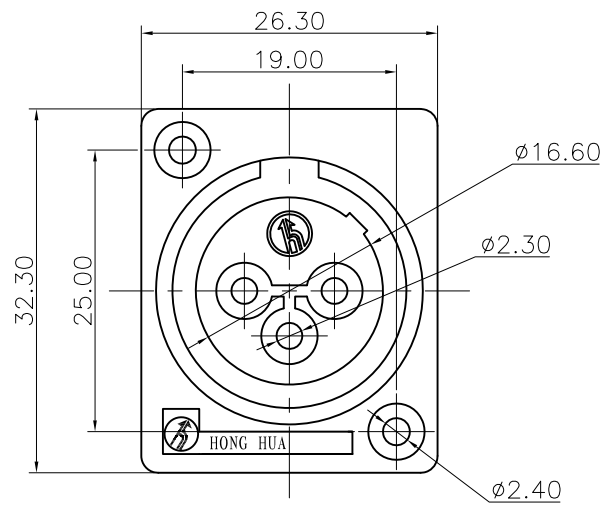
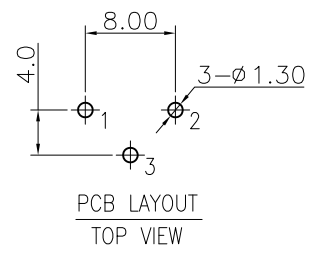
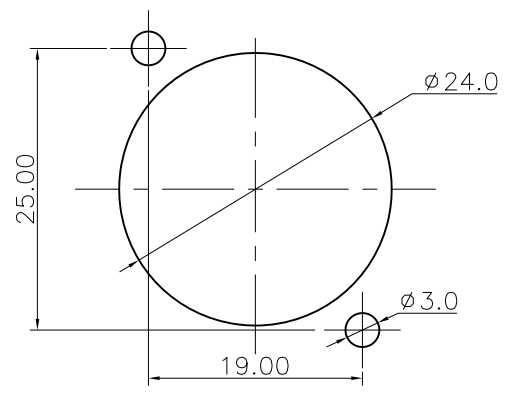

PANEL CUT OUT

PCB LAYOUT  
TOP VIEW

ANGLE	±5°	MODEL NAME: SPM-01A (PART NO.)		 广东正宝科技有限公司 GUANGDONG TRENPRO TECHNOLOGY CO. LTD.			
63 < L	±0.5	MAT'L: See table	DESIGN: X.H.Wang 08/28'18	TITLE: XLR CABLE CONNECTORS			
16 < L ≤ 63	±0.4			REV.: A			
4 < L ≤ 16	±0.3	FINISH: See table	CHECKED: L.W.Wu 08/28'18	DWG NO.:			
L ≤ 4	±0.2			UNIT: mm			
TOL TABLE:		Q'TY: /	APPROVED: X.Q.Hu 08/28'18	VIEW:	SCALE: 5:1	SHEET: 1/1	SIZE: A3
THIS DOCUMENT IS THE PROPERTY OF TRENPRO TECHNOLOGY CO. LTD. NO PART THEREOF MAY BE REPRODUCED AND USED WITHOUT THE PRIOR WRITTEN CONSENT OF THE OWNER				mm	VIEW:	SCALE: 5:1	SHEET: 1/1