

| | | | |
|------|---------|---------------|----------|
| REV. | ECN NO. | MODIFIED MARK | APPROVED |
| A | — | FIRST RELEASE | |

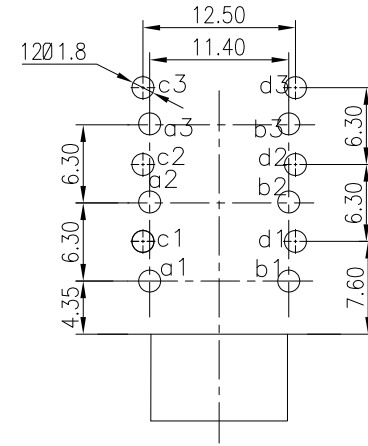
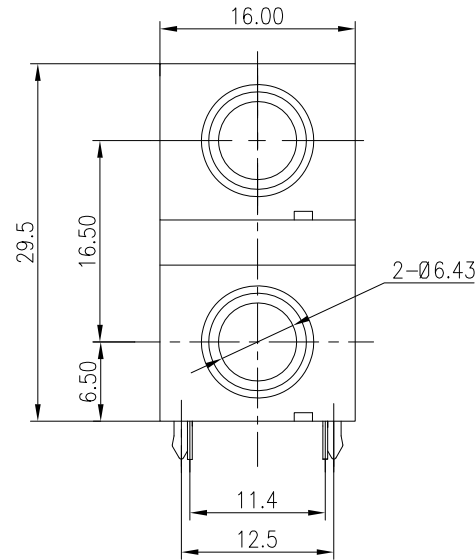
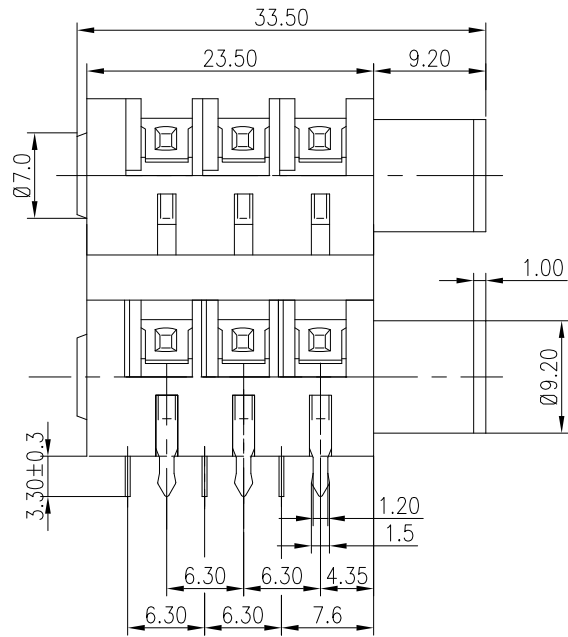

PCB LAYOUT
TOP VIEW

NOTES:

ELECTRICAL:

- 1:RATED CURRENT: 1A Max.
- 2:RATED VOLTAGE: 50V AC.
- 3:CONTACT RESISTANCE: 100 MILLIOHMS Max.
AFTER TESTING:100 MILLIOHMS Max.
- 4:INSULATION RESISTANCE: 100 MEGAOHMS Min.
- 5:DIELECTRIC WITHSTANDING VOLTAGE: 500 VAC Min.

MECHANICAL:

- 1:INSERTION FORCE: 5N-40N.
- 2:WITHDRAWAL FORCE: 5N-40N.
- 3:DURRABILITY: 5000 CYCLES.

ENVIRONMENTAL:

TEMPERATURE RANGE: -20°C TO 60°C.

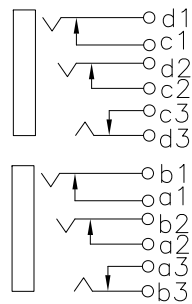

SCHEMATIC

| | |
|-------------|------|
| ANGLE | ±5° |
| 63 < L | ±0.5 |
| 16 < L ≤ 63 | ±0.4 |
| 4 < L ≤ 16 | ±0.3 |
| L ≤ 4 | ±0.2 |

TOL TABLE:
THIS DOCUMENT IS THE PROPERTY OF
TRENPRO TECHNOLOGY CO. LTD.,LTD.,NO
PART THEREOF MAY BE REPRODUCED AND
USED WITHOUT THE PRIOR WRITTEN
CONSENT OF THE OWNER

MODEL NAME: SJ6357K-2A
(PART NO.)

MAT'L:
See table
FINISH:
See table
Q'TY: /

DESIGN: Z.F.Lian 08/18'18
CHECKED: L.W.Wu 08/18'18
APPROVED: X.Q.Hu 08/18'18



广东正宝科技有限公司
GUANGDONG TRENPRO TECHNOLOGY CO. LTD.

TITLE: 6.35 PHONE JACK

DWG NO.:

UNIT: mm VIEW: SCALE: 5:1 SHEET: 1/1 SIZE: A3

REV.:
A