

REV.	ECN NO.	MODIFIED MARK	APPROVED
A	—	FIRST RELEASE	

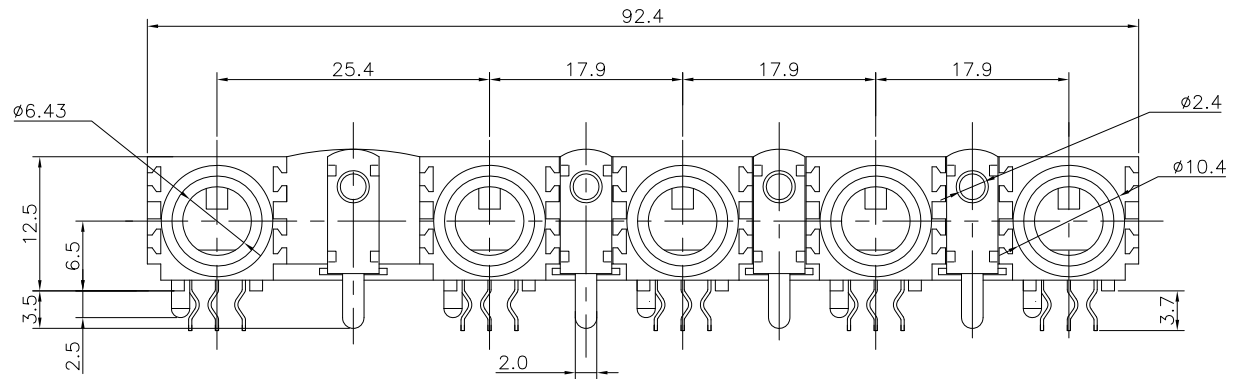

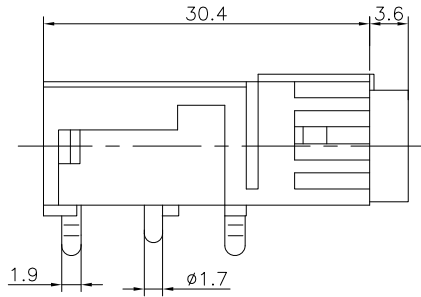

- NOTES:
- ELECTRICAL:
- 1:RATED CURRENT: 1A Max.
 - 2:RATED VOLTAGE: 50V AC.
 - 3:CONTACT RESISTANCE: 100 MILLIOHMS Max.
AFTER TESTING:100 MILLIOHMS Max.
 - 4:INSULATION RESISTANCE: 100 MEGAOHMS Min.
 - 5:DIELECTRIC WITHSTANDING VOLTAGE: 500 VAC Min.
- MECHANICAL:
- 1:INSERTION FORCE: 5N-40N.
 - 2:WITHDRAWAL FORCE: 5N-40N.
 - 3:DURRABILITY: 5000 CYCLES.
- ENVIRONMENTAL:
- TEMPERATURE RANGE: -20°C TO 60°C.

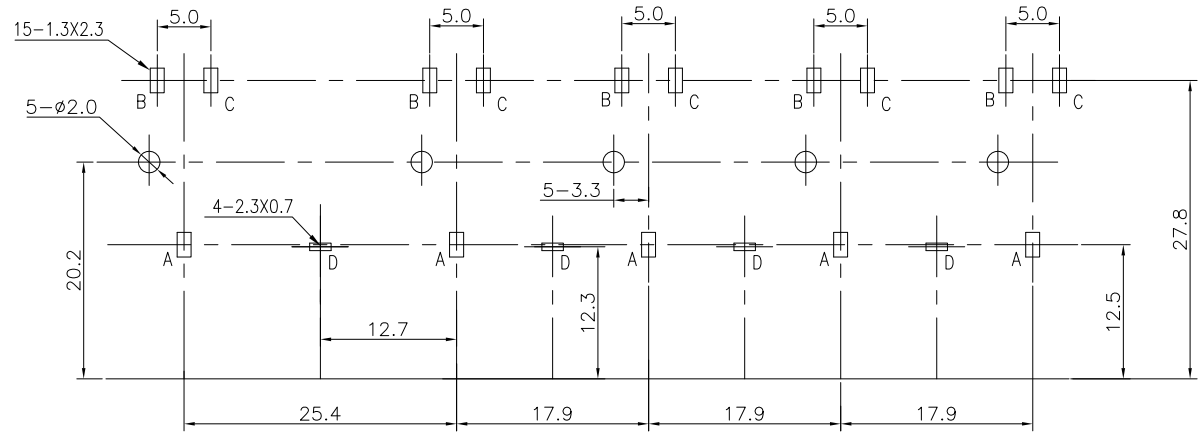

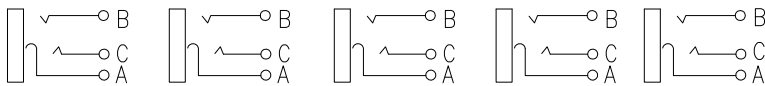
PCB LAYOUT
TOP VIEW



SCHEMATIC

ANGLE	±5°	MODEL NAME: SJ6355-5BA005 (PART NO.)	 广东正宝科技有限公司 GUANGDONG TRENPRO TECHNOLOGY CO. LTD.					
63 < L	±0.5							
16 < L ≤ 63	±0.4							
4 < L ≤ 16	±0.3							
L ≤ 4	±0.2							
TOL TABLE:		MAT'L: See table	DESIGN: X.H.Wang 10/18'18	TITLE: 6.35 PHONE JACK				
THIS DOCUMENT IS THE PROPERTY OF TRENPRO TECHNOLOGY CO. LTD.,NO PART THEREOF MAY BE REPRODUCED AND USED WITHOUT THE PRIOR WRITTEN CONSENT OF THE OWNER		FINISH: See table	CHECKED: L.W.Wu 10/18'18	DWG NO.:		REV.:		
		Q'TY: /	APPROVED: X.Q.Hu 10/18'18	UNIT: mm	VIEW: 	SCALE: 5:1	SHEET: 1/1	SIZE: A3