

REV.	ECN NO.	MODIFIED MARK	APPROVED
A	—	FIRST RELEASE	

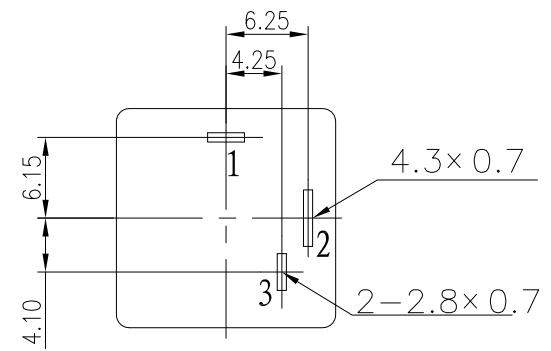

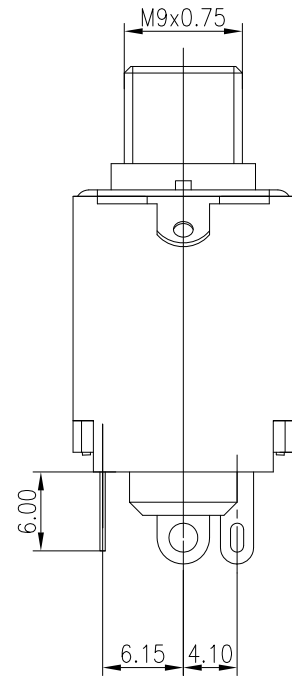

PCB LAYOUT
TOP VIEW

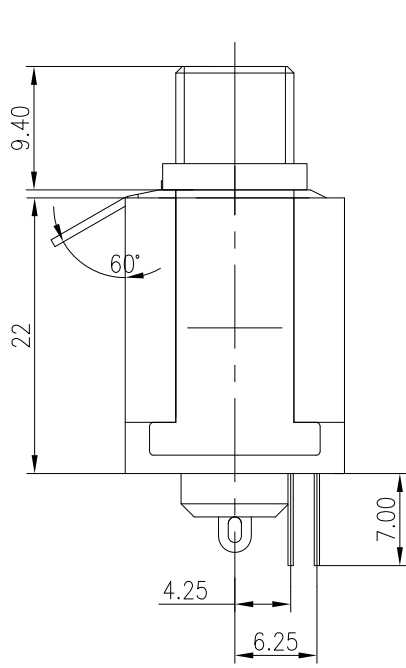
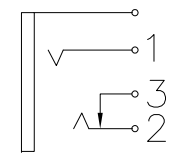
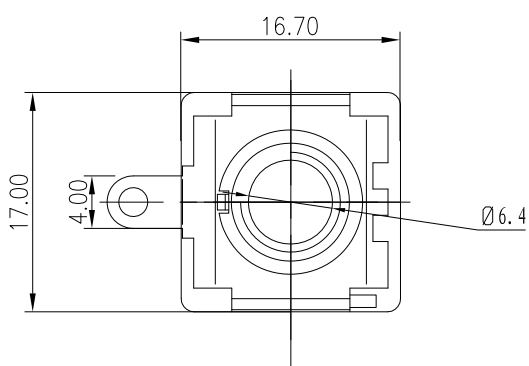

SCHEMATIC

NOTES:
ELECTRICAL:
1:RATED CURRENT: 1A Max.
2:RATED VOLTAGE: 50V AC.
3:CONTACT RESISTANCE: 100 MILLIOHMS Max.
AFTER TESTING:100 MILLIOHMS Max.
4:INSULATION RESISTANCE: 100 MEGAOHMS Min.
5:DIELECTRIC WITHSTANDING VOLTAGE: 500 VAC Min.
MECHANICAL:
1:INSERTION FORCE: 5N-40N.
2:WITHDRAWAL FORCE: 5N-40N.
3:DURRABILITY: 5000 CYCLES.
ENVIRONMENTAL:
TEMPERATURE RANGE: -20°C TO 60°C.

ANGLE	±5°	MODEL NAME: SJ6350B (PART NO.)		 广东正宝科技有限公司 GUANGDONG TRENPRO TECHNOLOGY CO. LTD.			
63 < L	±0.5	MAT'L: See table	DESIGN: X.H.Wang 09/20'18	TITLE: 6.35 PHONE JACK			
16 < L ≤ 63	±0.4			DWG NO.:			
4 < L ≤ 16	±0.3	FINISH: See table	CHECKED: L.W.Wu 09/20'18	REV.: A			
L ≤ 4	±0.2			Q'TY: /			
TOL TABLE:		APPROVED: X.Q.Hu 09/20'18	UNIT: mm	VIEW: 	SCALE: 5:1	SHEET: 1/1	SIZE: A3
THIS DOCUMENT IS THE PROPERTY OF TRENPRO TECHNOLOGY CO. LTD. NO PART THEREOF MAY BE REPRODUCED AND USED WITHOUT THE PRIOR WRITTEN CONSENT OF THE OWNER							