

| | | | |
|------|---------|---------------|----------|
| REV. | ECN NO. | MODIFIED MARK | APPROVED |
| A | — | FIRST RELEASE | |

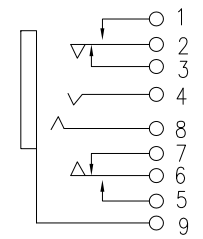

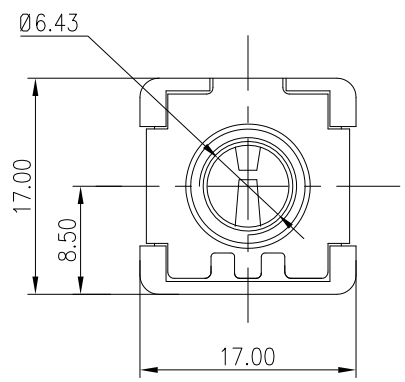

SCHEMATIC

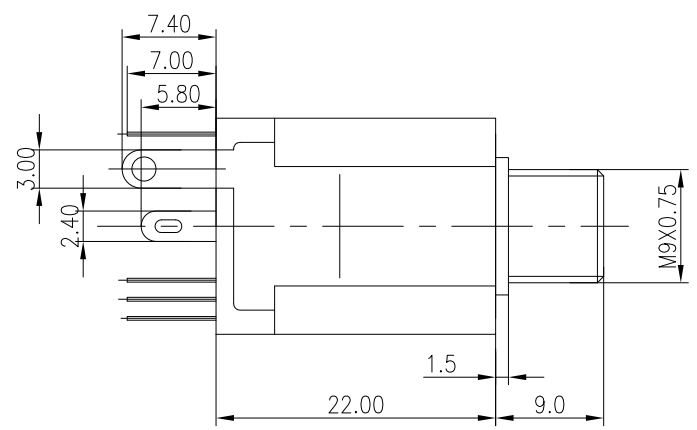
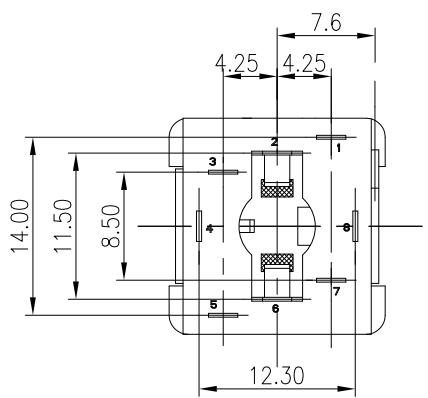
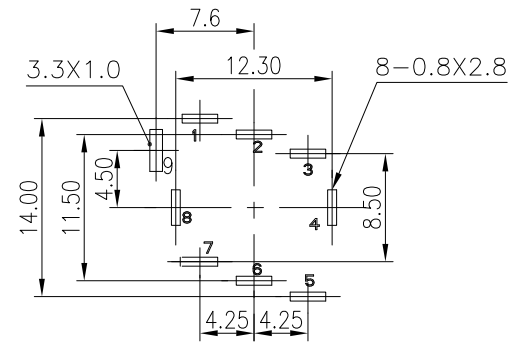
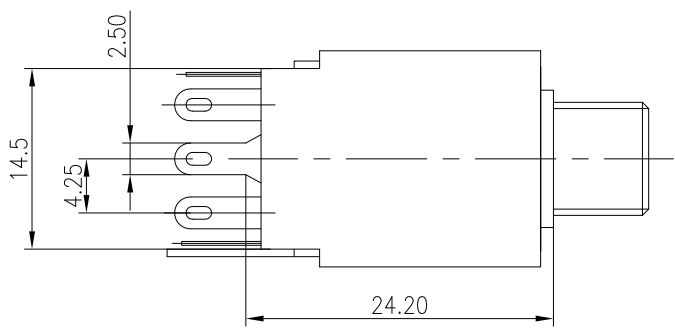

PCB LAYOUT
TOP VIEW

NOTES:
ELECTRICAL:
1:RATED CURRENT: 1A Max.
2:RATED VOLTAGE: 50V AC.
3:CONTACT RESISTANCE: 100 MILLIOHMS Max.
AFTER TESTING:100 MILLIOHMS Max.
4:INSULATION RESISTANCE: 100 MEGAOHMS Min.
5:DIELECTRIC WITHSTANDING VOLTAGE: 500 VAC Min.
MECHANICAL:
1:INSERTION FORCE: 5N-40N.
2:WITHDRAWAL FORCE: 5N-40N.
3:DURRABILITY: 5000 CYCLES.
ENVIRONMENTAL:
TEMPERATURE RANGE: -20°C TO 60°C.

| | | | | | |
|---|------|-----------------------------------|---|------------------------|---|
| ANGLE | ±5° | MODEL NAME: SJ6344A (PART NO.) |  广东正宝科技有限公司 GUANGDONG TRENPRO TECHNOLOGY CO. LTD. | | |
| 63 < L | ±0.5 | | | | |
| 16 < L ≤ 63 | ±0.4 | | | | |
| 4 < L ≤ 16 | ±0.3 | | | | |
| L ≤ 4 | ±0.2 | | | | |
| TOL TABLE: | | MAT'L: See table | DESIGN: X.H.Wang 09/20'18 | TITLE: 6.35 PHONE JACK | |
| THIS DOCUMENT IS THE PROPERTY OF TRENPRO TECHNOLOGY CO. LTD., NO PART THEREOF MAY BE REPRODUCED AND USED WITHOUT THE PRIOR WRITTEN CONSENT OF THE OWNER | | FINISH: See table | CHECKED: L.W.Wu 09/20'18 | DWG NO.: | REV.: A |
| | | Q'TY: / | APPROVED: X.Q.Hu 09/20'18 | UNIT: mm | VIEW:  |
| | | | | SCALE: 5:1 | SHEET: 1/1 |
| | | | | | SIZE: A3 |