

REV.	ECN NO.	MODIFIED MARK	APPROVED
A	—	FIRST RELEASE	

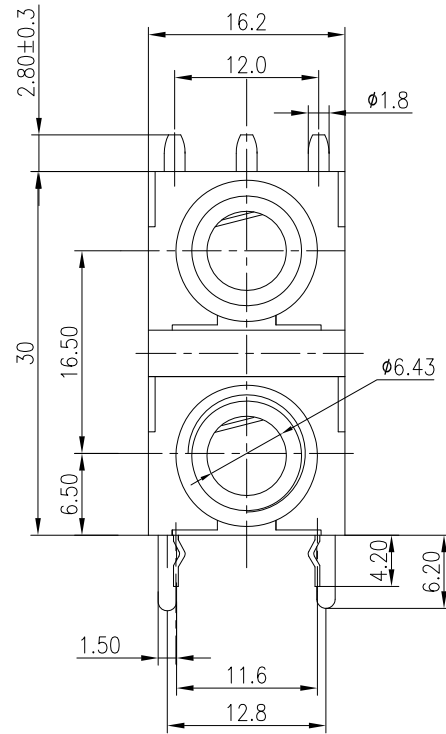

NOTES:
 ELECTRICAL:
 1:RATED CURRENT: 1A Max.
 2:RATED VOLTAGE: 50V AC.
 3:CONTACT RESISTANCE: 100 MILLIOHMS Max.
 AFTER TESTING:100 MILLIOHMS Max.
 4:INSULATION RESISTANCE: 100 MEGAOHMS Min.
 5:DIELECTRIC WITHSTANDING VOLTAGE: 500 VAC Min.
 MECHANICAL:
 1:INSERTION FORCE: 5N-40N.
 2:WITHDRAWAL FORCE: 5N-40N.
 3:DURRABILITY: 5000 CYCLES.
 ENVIRONMENTAL:
 TEMPERATURE RANGE: -20°C TO 60°C.

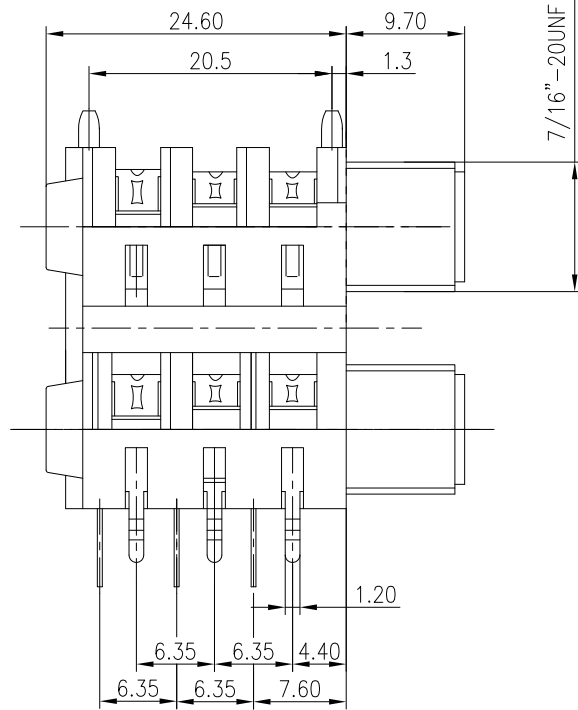
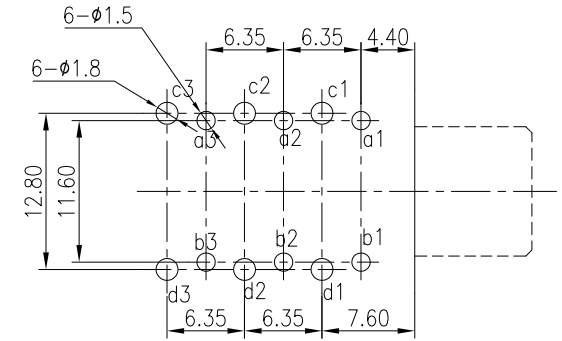

PCB LAYOUT
TOP VIEW

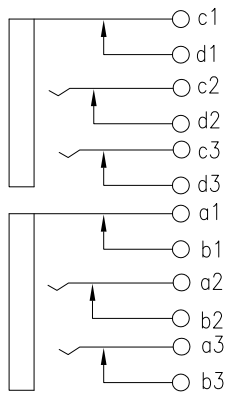

SCHEMATIC

ANGLE	±5°
63 < L	±0.5
16 < L ≤ 63	±0.4
4 < L ≤ 16	±0.3
L ≤ 4	±0.2
TOL TABLE:	
THIS DOCUMENT IS THE PROPERTY OF TRENPRO TECHNOLOGY CO. LTD.,LTD.,NO PART THEREOF MAY BE REPRODUCED AND USED WITHOUT THE PRIOR WRITTEN CONSENT OF THE OWNER	

MODEL NAME: SJ6337C
(PART NO.)



广东正宝科技有限公司
GUANGDONG TRENPRO TECHNOLOGY CO. LTD.

MAT'L:
See table

DESIGN: Z.F.Lian 08/28'18

TITLE: 6.35 PHONE JACK

FINISH:
See table

CHECKED: L.W.Wu 08/28'18

DWG NO.:

REV.:
A

Q'TY: /

APPROVED: X.Q.Hu 08/28'18

UNIT: mm

VIEW:

SCALE: 5:1

SHEET: 1/1

SIZE: A3