

ALLOWANCE	
UNDER 3	± 0.1
3 TO 6	± 0.15
6 TO 15	± 0.2
15 TO 50	± 0.25
50 OVER	± 0.3

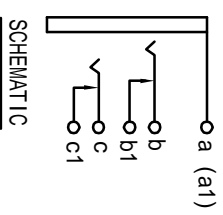
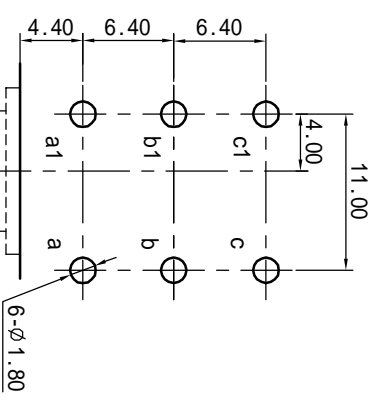
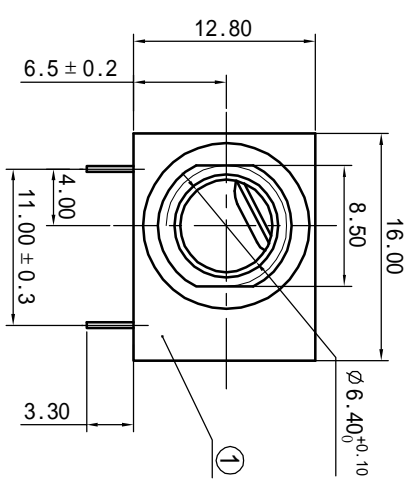
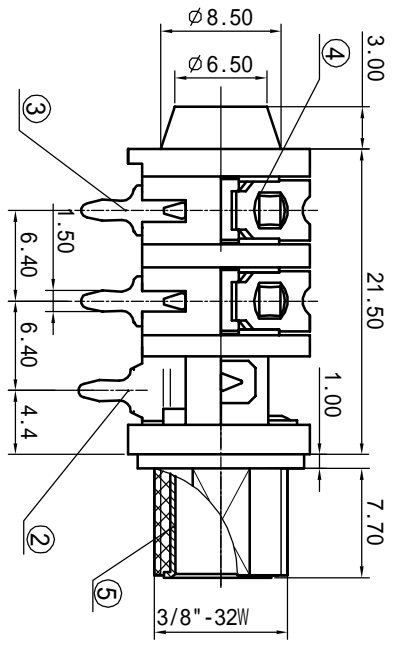
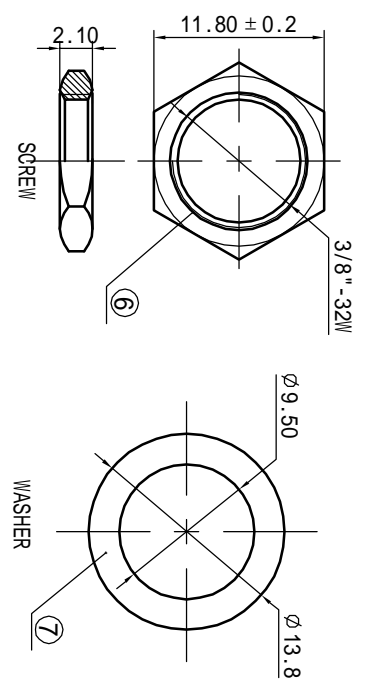
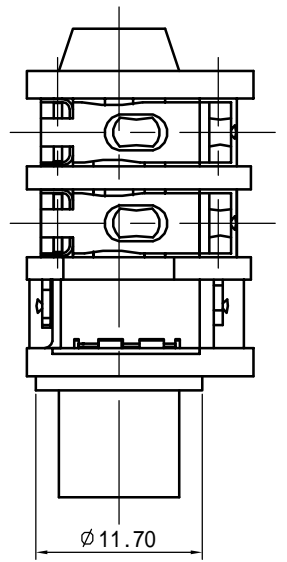

Specifications:  
 Rating :DC 50V, 1A.  
 Force:5-40N.  
 Contact resistance:  
 Less than30mΩ.  
 Insulation resistance:  
 Over 100MΩ on DC 500V  
 measured.  
 Voltage withstand :  
 AC 500V, For 1 minute.

NO.	PART NAME	MATERIAL	QTY	FINISHING
7	WASHER	SPCC t=0.5	1	NI PLATED
6	SCREW	BRASS	1	NI PLATED
5	SOCKET	BRASS	1	AU PLATED
4	TERMINAL-C	BRONZE t=0.4	2	AG PLATED
3	TERMINAL-B	BRASS t=0.4	2	AG PLATED
2	TERMINAL-A	BRASS t=0.4	1	AG PLATED
1	HOUSE	PA66	1	BLACK

MODEL NO : SJ-6346-6P	ALLOWANCE:	DRAWN BY:
TYPE : 6.35 PHONE JACK	UNIT : mm	CHECKED BY:
MATERIAL NO :	SCALE :	APPROVED BY:
PROJECTION		



**ZWEE CO., LIMITED**